



SPECIFICATIONS

SS-320CNH-300* CC DRIVER

Model: SS-320CNH-300*

Power: 320W

Rev.: V04

Release date: 2026-06-02



SS-320CNH-300* LED DRIVER

Features

- Efficiency up to 97%
- Isolated dimming: 0-10V, PWM, Resistor
- Optional aux: 12V/0.2A
- Programmable
- Time-controlled
- Dimming off without afterglow
- Standby Power<0.5W
- Protections: SCP/OTP/OVP/UVP
- Compatible with intelligent emergency controls
- Wide output voltage range,DIP-SW Power Range Programmable
- IP65
- Surge protection: CM: 6kV,DM: 6kV
- Long lifetime
- Warranty: 5 years



IP65

Description

SS-320CNH-300* series is 320W round non-isolated constant current LED driver. This series of products have the advantages of isolated dimming function, ultra-high efficiency, compact housing, fully potted, compatible with intelligent emergency control, good heat dissipation and waterproof performance, high reliability, high cost-effective and so on.

Applications:

industrial lighting, sports lighting

Model List

Model	AC Input Range	Max. Pout	Vout Range	Recommended Voltage	Iout	Default Current	THD (Typ.)	PF (Typ.)	Eff. (Typ.)	Max.Tc
SS-320CNH-300*	90-305Vac	320W	180-300V	200V-300V	0.4-1.5A	1.28A	7%	0.97	97%	90°C

Note:

1.Default Tested:at220Vac,fullload, Ta 25°C.

2.The performance of the LED Driver can be guaranteed within the full power Vo range.The voltage lower than full power Vo range, it is need to test the performance with the LED module.

SS-320CNH-300* LED DRIVER

“*” Means Additional Function

“*”	3Angle+3CCT +DIP Power	3CCT+DIP Power	DIP Power	AUX 12V suffix:H)	Dimming off 0-10V/PWM/Resistor	1-10V/PWM /Resistor (suffix:B)	Remark
BHB			✓	✓	✓		
BHD		✓		✓	✓		
BHT	✓			✓	✓		

Input Characteristics

Parameter	Min.	Typ.	Max.	Remark
Rated AC Input Range	100Vac		277Vac	Reference derating curve
AC Input Range	90Vac		305Vac	Reference derating curve
Input DC Voltage Range	140Vdc		280Vdc	
Input Frequency Range	47Hz	50/60Hz	63Hz	
Max Input Current			3.5A	108Vac, Full load
Max Input Power			350W	108Vac, Full load
Max Inrush Current(120Vac)			60A	Cold start
Max Inrush Current(220Vac)			105A	Cold start
Max Inrush Current(277Vac)			140A	Cold start
Standby Power			0.5W	220Vac, Dim-to-of (BHB/BHD/BHT models)
Power Factor	0.95	0.97		220Vac, Full load
	0.90			100-277Vac,70%-100% load
THD		7%	12%	220Vac, Full load
			20%	100-277Vac,70%-100% load

SS-320CNH-300* LED DRIVER

DIP switches:

BHD 3CCT+DIP Power

CCT	Power
WW	200W
NW	240W
CW	320W

BHB DIP Power

Power
200W
240W
320W

BHT 3Angle+3CCT+DIP Power

ANG	CCT	Power
SA	WW	200W
MA	NW	240W
BA	CW	320W

CW: white light NW: mixed light WW: warm light

SA: small angle MA: medium angle BA: large angle

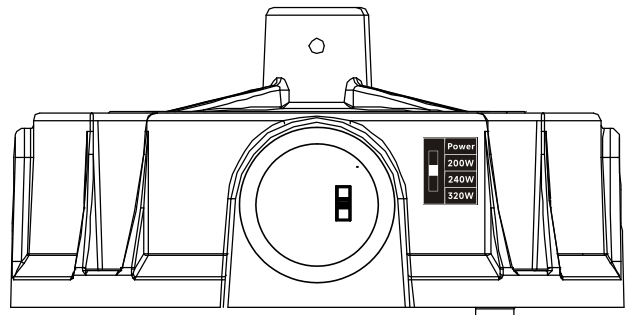
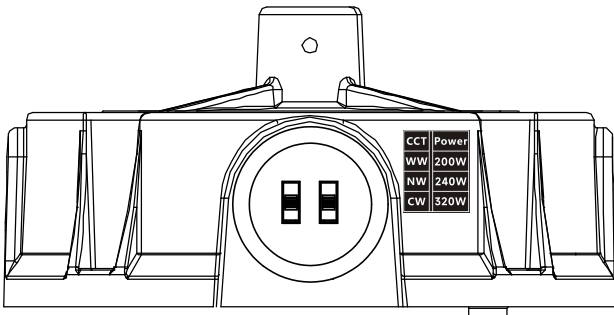

If 2CCT is required, please add the following Mylar tabs to be affixed above the toggle code.

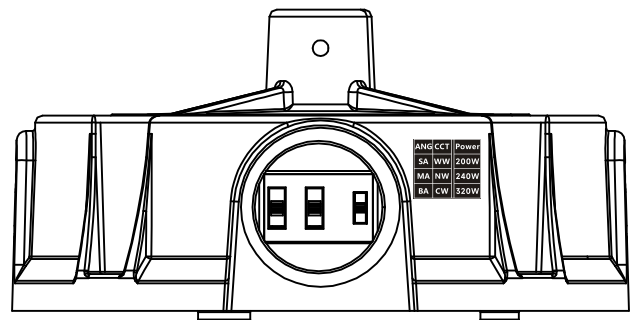
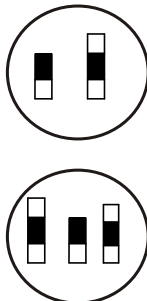

Note:
Adjusting the angle, power and color temperature need to be operated after the input power is disconnected.

SS-320CNH-300* LED DRIVER

Instructions for using the BHT triple-dial code:

Structural Appearance

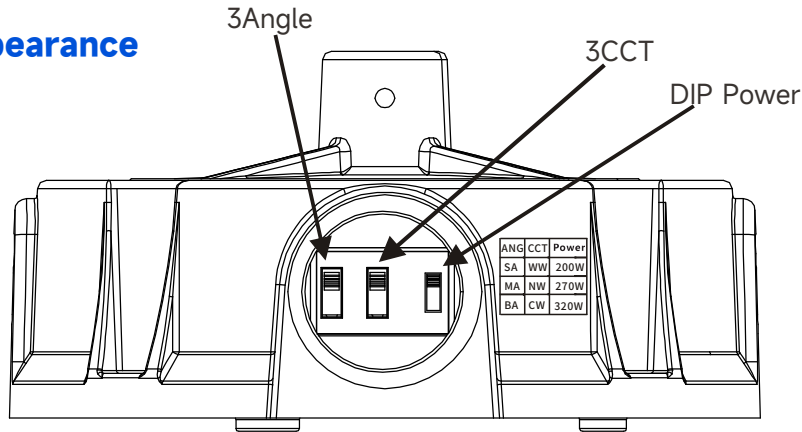

As shown in the figure, the 3CCT from top to bottom: WW, NW, CW (warm light, mixed light, cold light) 3Angle from top to bottom: SA, MA, BA (small angle, medium angle, large angle) DIP Power from top to bottom: gradually larger

Wiring method.

Red VOUT1+, Brown VOUT2+, Blue VOUT1-, Black VOUT2-

The dialing schematic diagram illustrates.

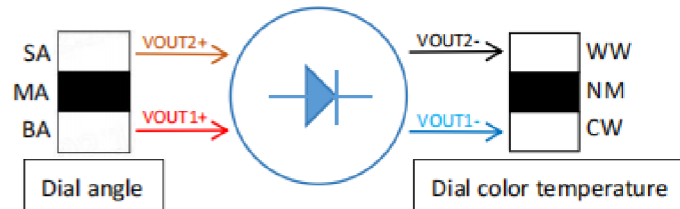

Output positive electrode	Output negative pole	Output state	Angle state	color temperature state
RED VOUT1+	BLUE VOUT1-	on	BA	CW
RED VOUT1+	BLACK VOUT2-	on	BA	WW
RED VOUT1+	BLUE VOUT1-&BLACK VOUT2-	on	BA	NW
BROWN VOUT2+	BLUE VOUT1-	on	SA	CW
BROWN VOUT2+	BLACK VOUT2-	on	SA	WW
BROWN VOUT2+	BLUE VOUT1-&BLACK VOUT2-	on	SA	NW
RED VOUT1+&BROWN VOUT2+	BLUE VOUT1-	on	MA	CW
RED VOUT1+&BROWN VOUT2+	BLACK VOUT2-	on	MA	WW
RED VOUT1+&BROWN VOUT2+	BLUE VOUT1-&BLACK VOUT2-	on	MA	NW

SS-320CNH-300* LED DRIVER

Output Characteristics

Parameter	Min.	Typ.	Max.	Remark
O/P Voltage Range	180V		300V	Power derated @180-200V
Rated O/P Voltage	214V		300V	Po=Vo*Io=320W, Full load
Rated O/P Current	1.06A		1.5A	1.5A for 214V,1.06A for 300V
Adj. O/P Current (AOC)Range	1.06A		1.5A	1.06A
	0.9A		1.26A	0.9A
	0.667A		0.93A	0.667A
No Load Voltage			350V	
Efficiency @120Vac	92.0%	94.0%		Output 300V/1.06A
Efficiency @220Vac	94.0%	96.0%		Output 300V/1.06A
Efficiency @277Vac	95.0%	97.0%		Output 300V/1.06A
O/P Current Tolerance	-5%		+5%	
O/P Current Ripple(PK-AV)		5%	10%	
Start-up Current Overshoot			10%	Full load
Start-up Time			1.2S	120Vac
			0.5S	220Vac
Line Regulation	-3%		+3%	Full load
Load Regulation	-5%		+5%	
Temperature Coefficient	-0.06%/°C		+0.06%/°C	Tc:0°C~90°C
OTP	90°C	93°C	96°C	Drop current when OTP, and it can be automatically restored after the abnormality is removed.
Short Circuit Protection				Driver will not be damaged

SS-320CNH-300* LED DRIVER

Other Characteristics

Parameter		Min.	Typ.	Max.	Remark
Aux Power	O/P Voltage	10.8V	12V	13.8V	
	O/P Current			200mA	
0-10V Dimming (Optional)	Dim Vmax	0V		12V	DIM+ source current 110uA.
	Dim Range	10%lomax		100%loset	Dimming prohibits reverse connection
	Rec.Dim Range	0V		10V	
PWM Dimming (Optional)	PWM High	9.8V		10.2V	DIM+ source current 110uA.
	PWM Low	0V		0.3V	Dimming prohibits reverse connection
	Frequency	1KHz		2KHz	
	PWM Duty	0%		100%	
Resistor Dimming (Optional)	Resistance	0Kohm		100Kohm	DIM+ source current 110uA.
	Dim Range	10%lomax		100%loset	
Dim to Off	Dim off	0.7V	0.8V	0.9V	Auxiliary source 12V unloaded, no afterglow
	Dim on	0.9V	1.0V	1.1V	
Intelligent Emergency Control (Optional, off by default)	Emergency switchover time	3S			AC power failure switching to battery power supply time
	Output Current		8%	10%	Emergency output current can be set via PC software
	Auto-exit time		2H/3H		When the sensor does not detect a signal configurable
	Access to emergency communications	4Hz duty cycle 25%, high level: 4-10V, low level: 0-0.3V			Duration 30S
	Withdrawal from emergency communications	1Hz duty cycle 25%, high level: 4-10V, low level: 0-0.3V			Duration 2H; configurable
Timing Curve(Optional)	By programming			Set by program	
Lifetime(Tc≤85°C)	≥50,000 hours			80% load	
MTBF	198,000 hours			220Vac,Full load, Ta=25°C (MIL-HDBK-217F)	
Protection class	IP65				
Tc	90°C				
Warranty	5 years			Tc 85°C	
Net Weight	1340g			Input line: 300mm	
Dimension	Φ146mm*66.5mm			WxH	

NOTE: All the parameters above are tested Ta 25°C and LED load, unless specified.

SS-320CNH-300* LED DRIVER

Environmental Requirements

Parameter	Min.	Typ.	Max.	Remark
Operating Temperature(Tcase)	-40°C	25°C	+90°C	
Storage Temperature	-40°C	25°C	+90°C	
Operation Humidity	10%RH		90%RH	
Storage Humidity	5%RH		95%RH	
Altitude	-65m		4000m	

Safety and EMI/EMS Standards

Certification	Standard	Status	Remark
UL/cUL	UL8750	✓	
ENEC	EN 61347-1 EN 61347-2-13 EN IEC 62384	✓	
RCM	AS/NZS61347.2.13	✓	
CCC	GB 19510.14		
CE	EN 61347-2-13 EN61347-1	✓	

EMI/EMS	Criterion	Remark
Conduction Emission	EN IEC 55015	230Vac
	FCC Part 15 Subpart B; ANSI C63.4	120Vac: Class B
Radiation Emission	EN IEC 55015	230Vac
	FCC Part 15 Subpart B; ANSI C63.4	120Vac: Class B
Harmonic Current Emissions	IEC/EN 61000-3-2	Class C
Surge	IEC/EN61000-4-5	DM: 6kV,CM: 6kV,Criterion B
Ring Wave	IEC/EN 61000-4-12	DM: 6kV,CM: 6kV,Criterion B

SS-320CNH-300* LED DRIVER

Safety Test Items

Safety Test Items	Technical Indicators			Remark
Insulation Requirements	UL Insulation Requirements	TUV Insulation Requirements	CCC Insulation Requirements	
Input-Case	2U+1000Vac	2U+1000Vac	/	Basic insulation
Input-Dim	2U+1000Vac	4U+2000Vac	/	Reinforced insulation
Dim-Case	500Vac	500Vac	/	Basic insulation
Insulation Resistance	≥10MΩ			Input-Dim, Test voltage:500Vdc
Ground Resistance	≤0.1Ω			25A/1min
Leakage Current	≤0.75mA			277Vac

Note:

1. The power supply complies with the relevant EMC standards. The power supply, as part of the terminal equipment system, needs to be combined with the whole system to reconfirm EMC.
2. During voltage withstand test, please short-circuit between L/N, short-circuit between positive/negative output line, and short-circuit between positive/negative dimmer line and auxiliary power supply.

Performance Curves

Input Inrush Current

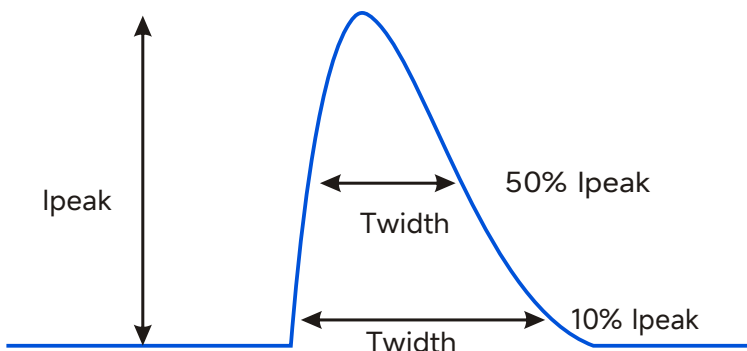

Vin	Ipeak	T(@10% of Ipeak)	T(@50% of Ipeak)
120Vac	60A	600uS	200uS
220Vac	105A	500uS	200uS
277Vac	140A	500uS	200uS

SS-320CNH-300* LED DRIVER

Performance Curves

Output Voltage Vs. Output Current(Dim/AOC Window)

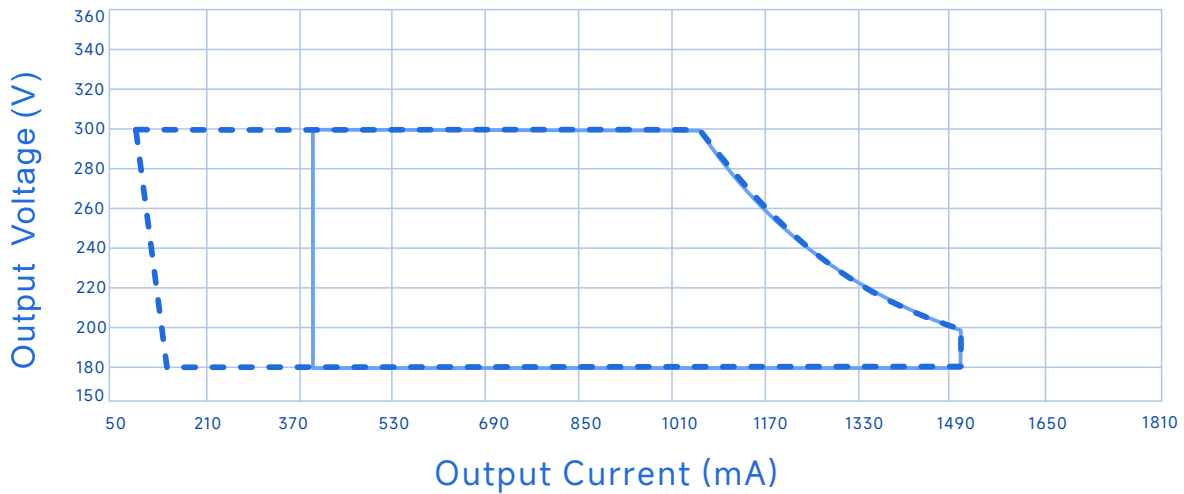

----- Dimming Window ————— AOC Window

Efficiency Vs. Output Voltage($V_{in}=120V_{ac}$)

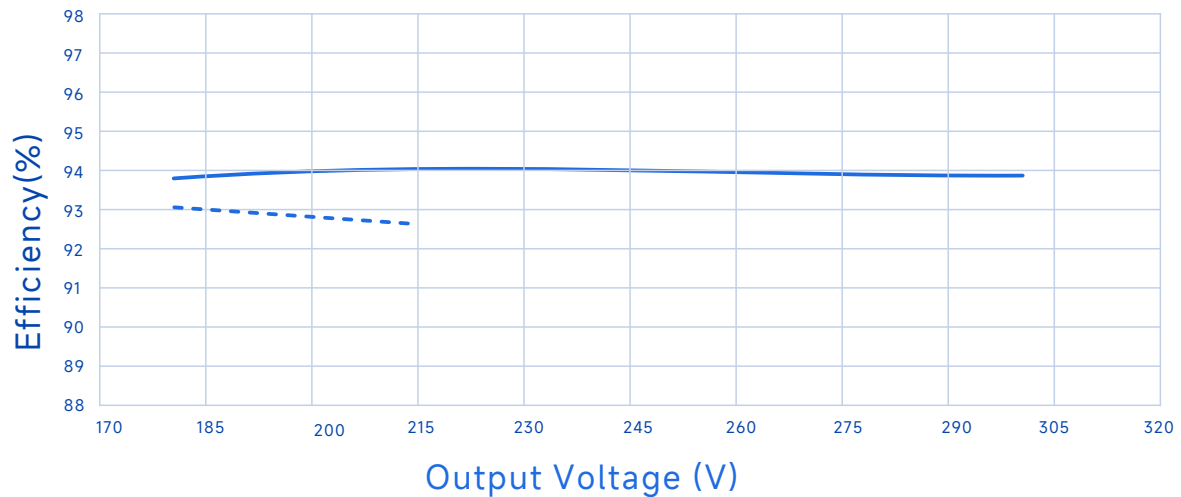

----- $I_o=1500mA$ ————— $I_o=1060mA$

SS-320CNH-300* LED DRIVER

Performance Curves

Efficiency Vs. Output Voltage (Vin=220Vac)

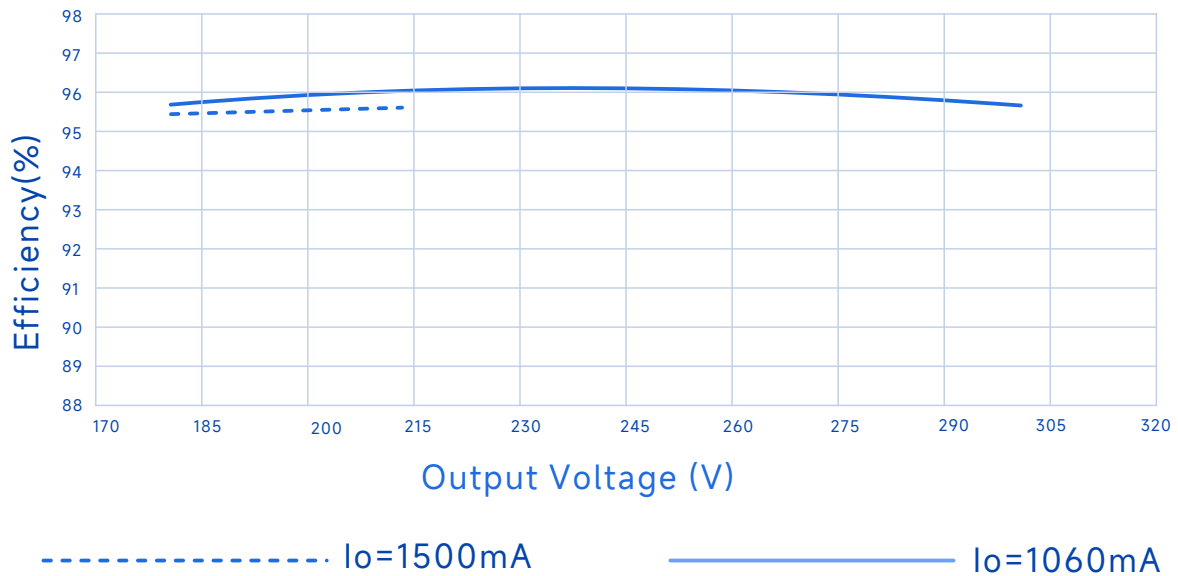

Efficiency Vs. Output Voltage (Vin=277Vac)

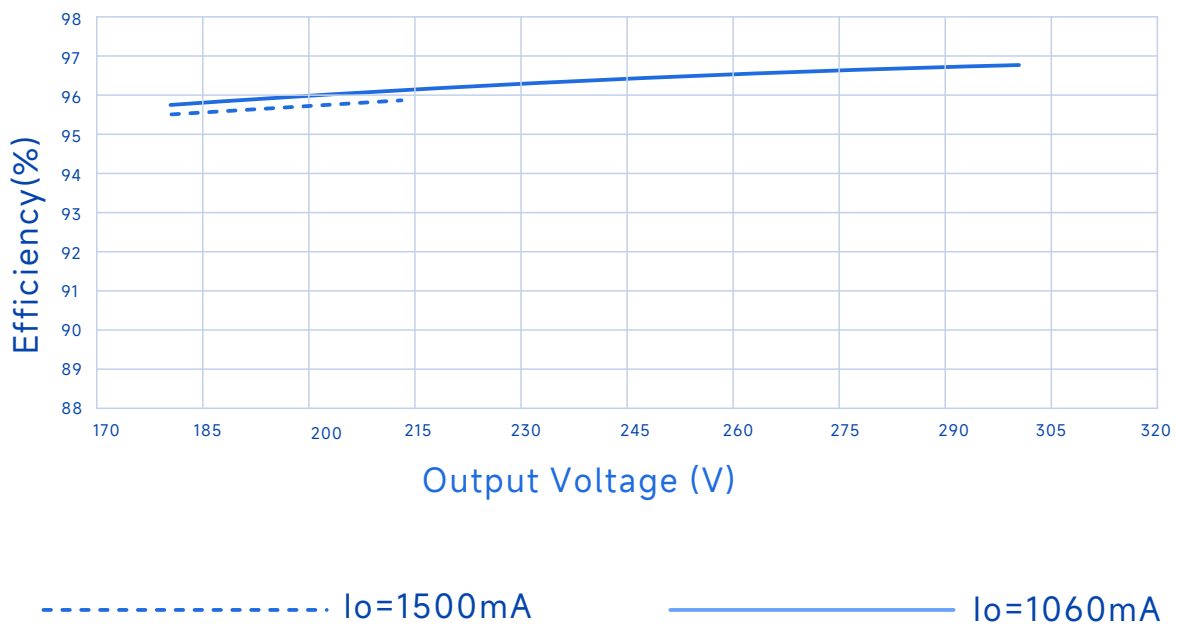

SS-320CNH-300* LED DRIVER

Performance Curves

Power Factor Vs. Output Power

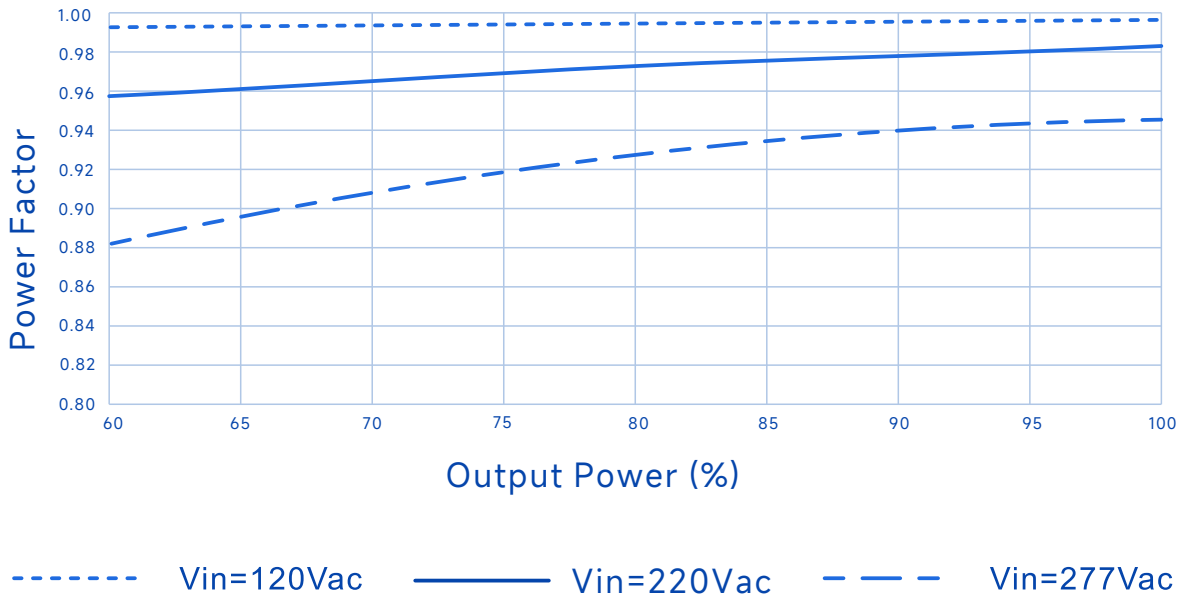

THD Vs. Output Power

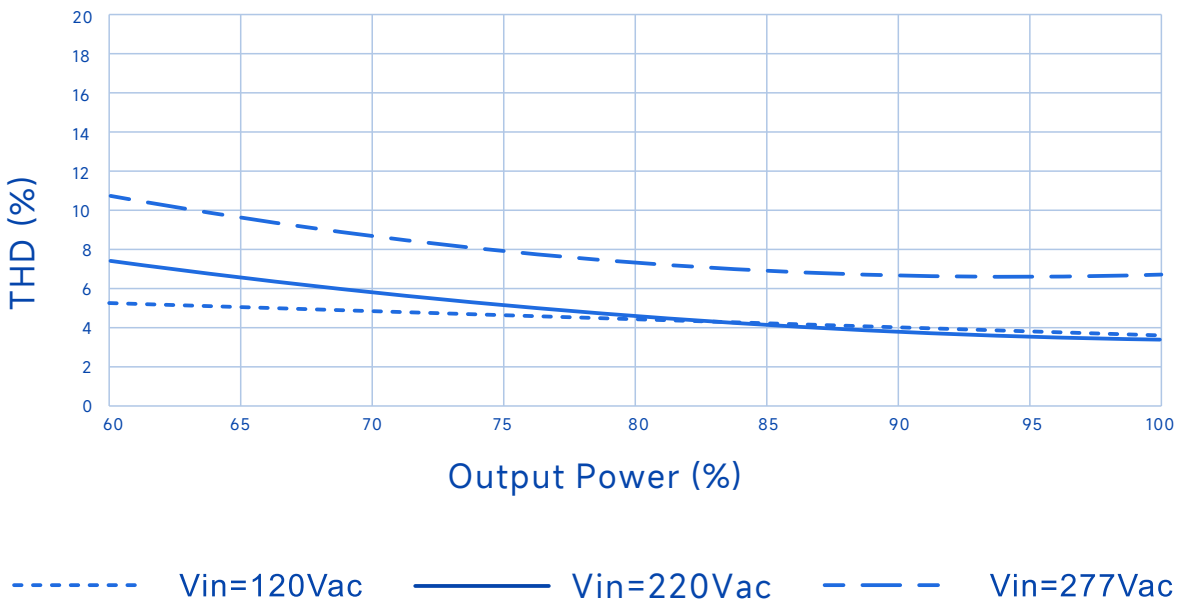

SS-320CNH-300* LED DRIVER

Performance Curves

Output Power Vs. Input Voltage

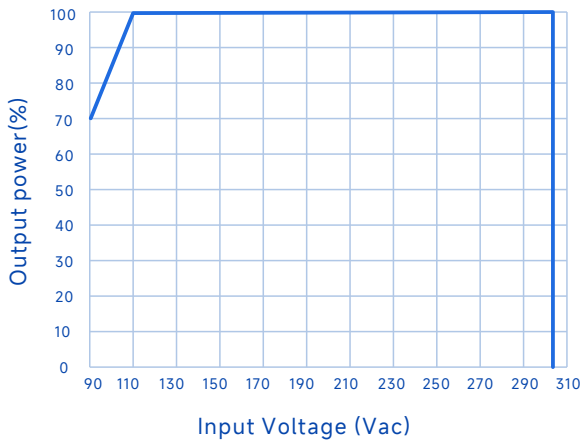

Output Power Vs. Case Temperature

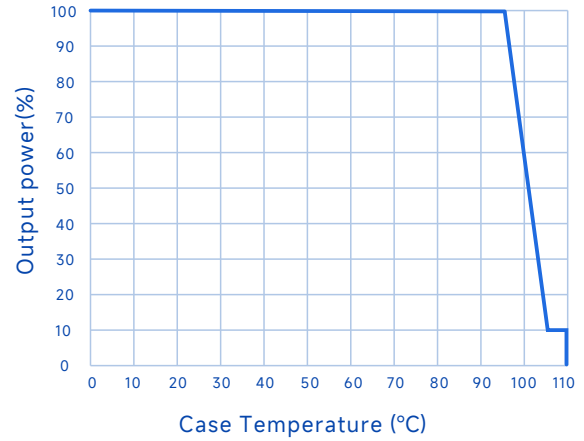

Output Power Vs. Dimming

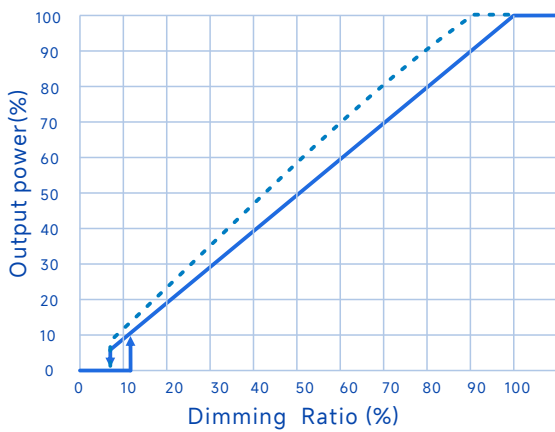

Lifetime Vs. Case Temperature

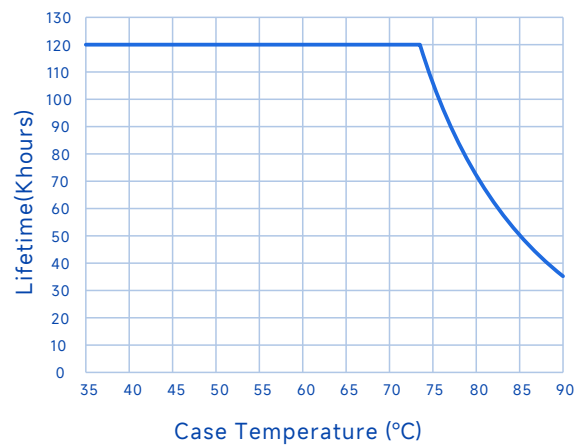

BHB/BHD/BHT:

— 0-10V ,PWM Dimming - - - Resistor Dimming

SS-320CNH-300* LED DRIVER

Programming connection diagram

Legacy Timer: Driver's O/P follows the pre-programmed timing curve after turn-on.

Auto-Adjust by Percentage: Driver's O/P will be adjusted by automatically changed dimming curve by the period percentage based on the latest 5 dimming curve.

Auto-Adjust by Mid-point: Driver's O/P will be adjusted by automatically changed dimming curve by mid-point based on the latest 5 dimming curve.

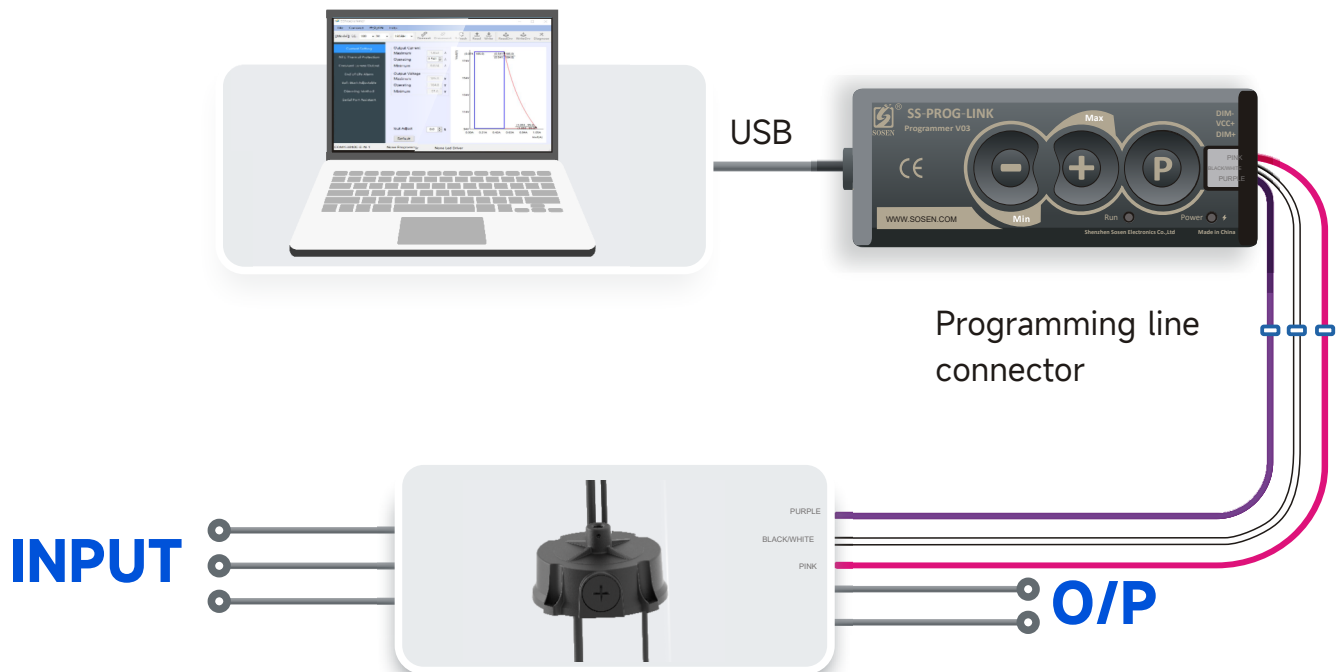

Note:

During the lifetime of the LED lamp, the driver continuously adjusts to increase the output optical power, thus ensuring that the LED lamp still has a constant optical power output after a long period of operation.

SS-320CNH-300* LED DRIVER

Mechanical Characteristic

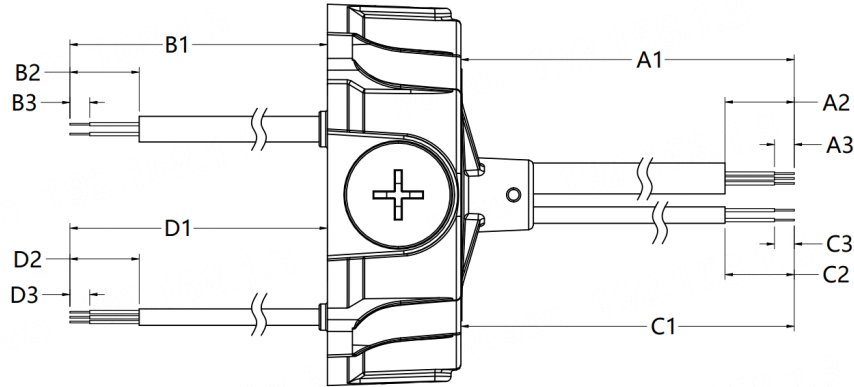

Optional wires kind	AC Input Cable (mm)			DC output Cable mm			UP Dimming Cable mm			Down Dimming Cable mm		
	A1	A2	A3	B1	B2	B3	C1	C2	C3	D1	D2	D3
1#	1830±10	45±5	8	200±10	22±3	9±1	1830±10	45±5	10±2	200±10	22±3	9±1
2#	1530±10	45±5	8	200±10	22±3	9±1	1530±10	45±5	10±2	200±10	22±3	9±1
3#	300±10	45±5	8	200±10	22±3	9±1	300±10	45±5	10±2	200±10	22±3	9±1

AC Input Cable	DC output Cable	UP Dimming Cable	Down Dimming Cable
Global model SJOW, 3 *18AWG, O.D.:8.0mm, Brown:ACL, Blue:ACN, Yellow/Green:⊕;	BHB: SJOW, 2 *17AWG, O.D.:7.7mm, Brown:V+, Blue:V-; BHD: SJOW, 3 *17AWG, O.D.: 8.0mm, Brown: LED+, Blue: LED1- (Warm light), Black: LED2- (White light); BHT: SJOW, 4*17AWG, Red: V1+(Large angle); Brown: V2+ (Small angle); Blue: V1- (Cool light); Black: V2- (Warm light);	BHB/BHD/BHT: UL 21996 3*22AWG Purple: DIM+, Pink: DIM- Black/White: Vaux+;	UL/EU/Global : UL 21996 3*22AWG Purple: DIM+, Pink: DIM- Black/White: Vaux+;

SS-320CNH-300* LED DRIVER

Mechanical Characteristic

Name Description	Standard Code	mm(In.)
Fixing screw hole diameter	4-B	Φ6.5(0.26)
Housing Diameter	D	Φ146(5.74)
Enclosure height	H	66.5(2.62)
Eyelet hole (optional)	Z	M10*1.5(depth20mm) G1/2(depth20mm)
Eyebolt Holes	R	M4*0.7
Mounting hole size	W	132(5.2)
Tc point location	Y	30(1.2)

Note

1, Please follow the "LED Driver User Manual" obtained from SOSEN's official website for assembly.

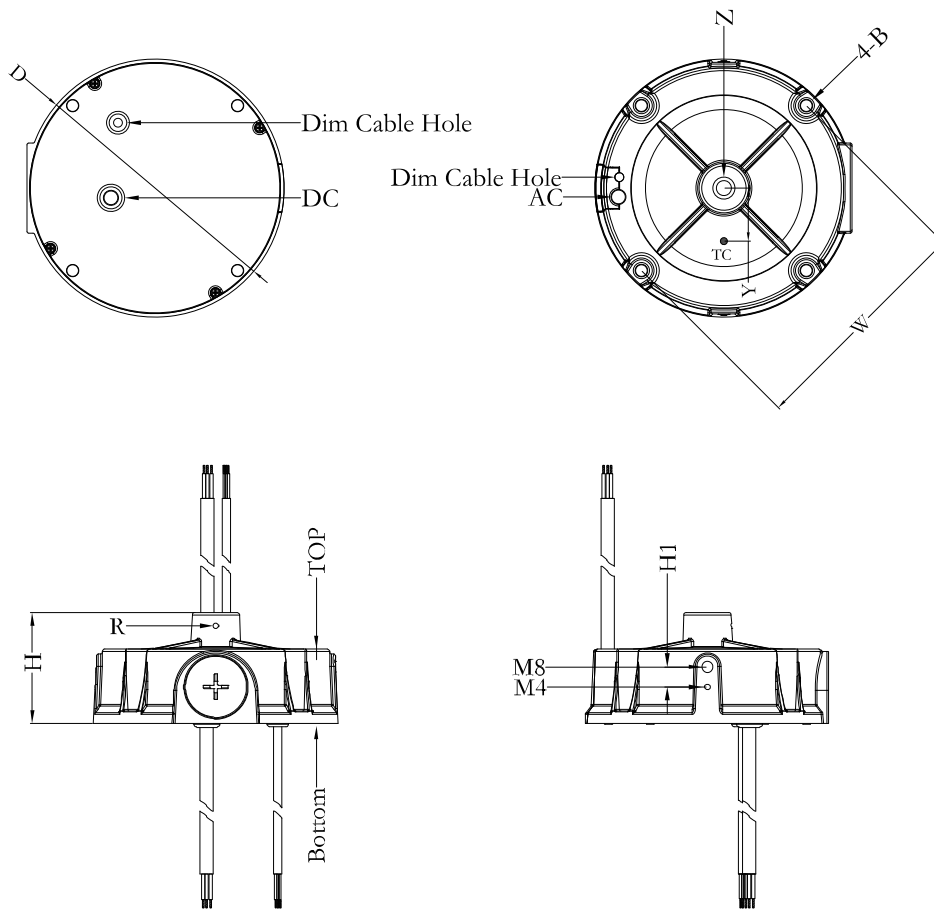

SS-320CNH-300* LED DRIVER



Assembly Tips

- 1.If the product has an external adjustable potentiometer, please adjust the current, it is recommended to use 704 silicone to adjust the current of the potentiometer. Seal the hole of adjusting current with 704 silicone and cover it with waterproof rubber plug.
- 2.When the dimmer line is not in use, please seal the connector of the dimmer line with insulating sleeve, so as not to string into the interfering signals and cause damage to the dimmer line, affecting the power supply. dimming line damage, affecting the normal operation of the power supply.
- 3.The trace routing on aluminum substrates is designed in compliance with creepage distance requirements specified by relevant certification regulations.
- 4.The creepage distance between LED+ and LED- on the aluminum substrate is designed in compliance with the relevant certification regulations.
5. aluminum substrate to minimize the laying of copper area, reduce junction capacitance, reduce leakage current.
6. LED lamp bead arrangement is recommended first and then string.
7. LED light board insulation level should meet the reliability design requirements.
- 8.other notes, please refer to the "LED driver power supply instruction manual".

Warning

Insufficient or compromised insulation voltage resistance in LED light panels may cause breakdown and short circuits to earth, resulting in damage to the luminaire and LED driver, and posing significant safety hazards. It is recommended to install a residual current device (RCD) during application.

Package

- Outside carton dimension: L×W×H =577mm×385mm×162mm;
- 9PCS/Carton;
- Net weight/Piece: 1.34kg;Gross weight/Carton: 13.235kg;
- Please refer to the product name, model number, manufacturer identification, QC PASS, manufacturing date on the package.

Transportation

Packaging is designed suitable for transportation by trucks, vessels and flights. The products should be avoided direct sunlight and rain, loaded/unloaded with caution.

Storage

The product storage meets the standard of the GB 3873 83.
Products should be rechecked if stored for over 1 year before assembly.

RoHS

Products comply with RoHS Directive (2011/65/EU) and amendment 2015/863/EU.

Revision History

Version	Description of Update	Updated Date	Remark
V00	Original Release	2025/09/05	
V01	Update certification, default current	2025/12/16	
V02	Update Assembly Tips	2026/01/15	
V03	Update cables	2026/03/25	
V04	Update the authentication token	2026/06/02	